

1 Ground Floor Plan
1 : 100

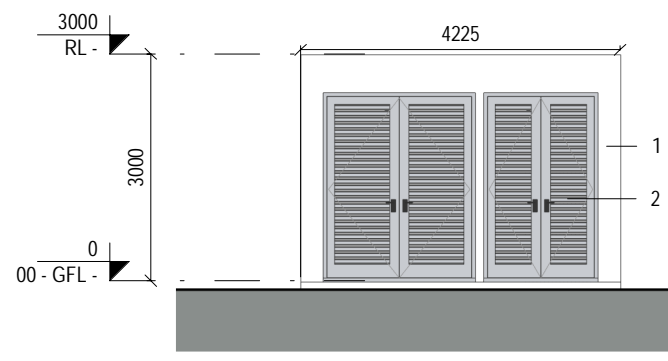

2 Front Elevation
1 : 100

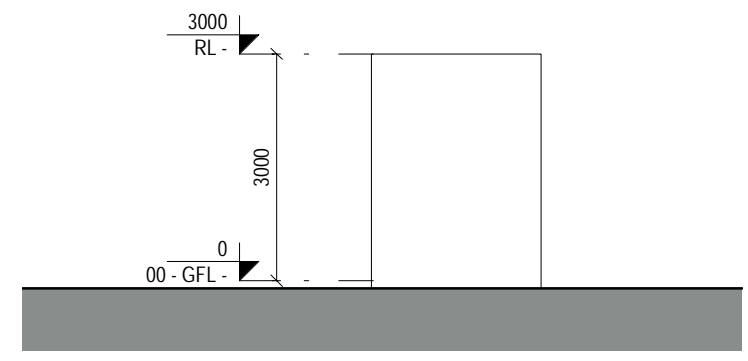

3 Side Elevation A
1 : 100

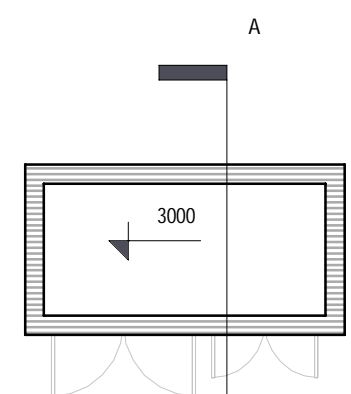

5 Roof Plan
1 : 100

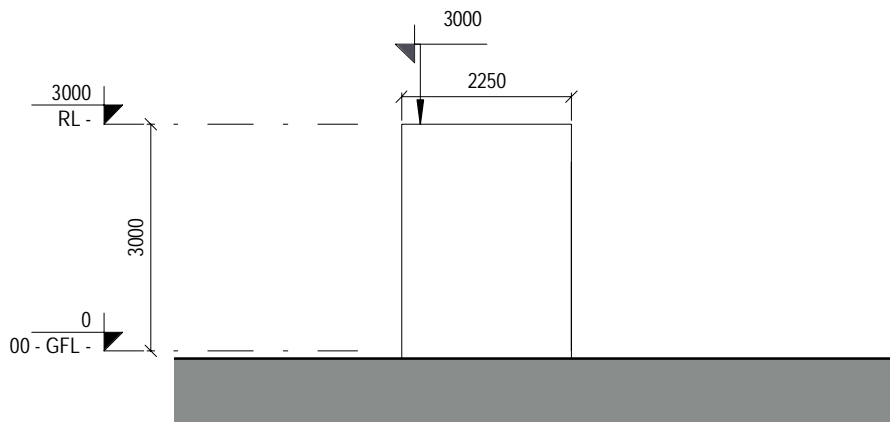

6 Side Elevation B
1 : 100

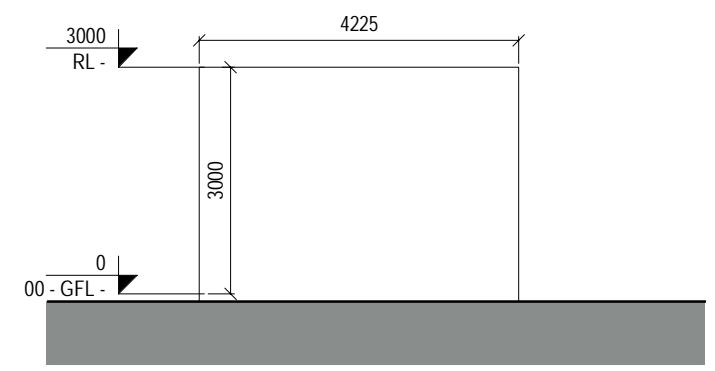

7 Rear Elevation
1 : 100

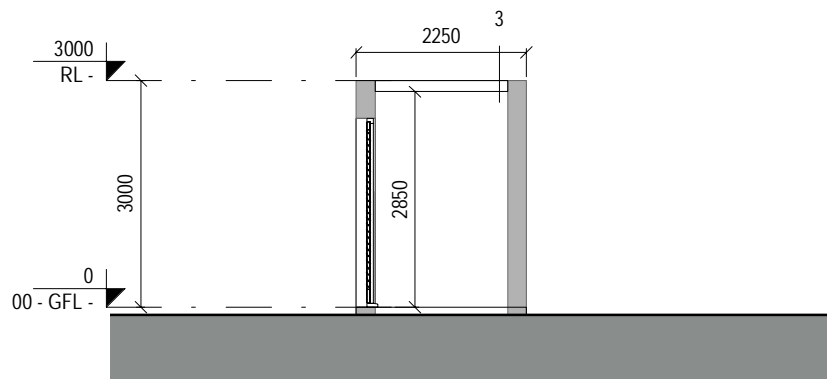

8 Section A-A
1 : 100



SHD APPLICATION

REV	DATE	DESCRIPTION	BY
1	15/05/2020	Revised Plans & Elevations	AR
2	24/06/2020	Updated Titleblock	AR

Note:
 *Please refer to Site Plan for Ground Floor Levels and North Point Location
 *Levels on this sheet taken from temporary benchmark at 0.0

- MATERIALS LEGEND**
- 1 - Sand / cement render
 - 2 - Selected Treated Steel Doors
 - 3 - Selected Trellis Timber Structure

NORTH POINT

ONLY FOR REFERENCE WITH PLAN DRAWINGS

APPROVED

Client: BURKEWAY HOMES LTD
 Project: BEARNA RESIDENTIAL DEVELOPMENT
 Title: BICYCLE STORE 2 - PLANS, ELEVATIONS & SECTION

Sheet No.: 924-MDO-BK2-ZZ-DR-A-02001
 Scale as: 1:100 Current Rev.: 2 Project No.: 924

MC CAULEY DAYE O'CONNELL
 ARCHITECTS

11 Merrion Square, Dublin 2, Ireland
 Telephone: +353 (0)1 400 4171
 info@mco.ie | www.mco.ie